



SK+/SPK+ – The NEW Precision

Low-Backlash Right-Angle Gearhead



alpha

a WITTENSTEIN AG company

SK+/SPK+ – unlimited freedom

The new SK+ and SPK+ right-angled gearhead series from **alpha** boasts a number of unique characteristics that create crucial new design freedoms for you and your machine.

The limitations inherent in traditional bevel-type gearheads are now a thing of the past. The + achieves more torque, lower noise levels and higher productivity.

An awe-inspiring experience.



The benefits at a glance: High-Speed continuous duty in the packaging industry, dynamic cyclic operation in automation engineering, precise positioning in production machines, optimum running in roller drives for printing and converting.

Our state-of-the-art SK+ and SPK+ right-angled gearhead offers you unlimited technical and commercial freedom!



SK+/SPK+ – You've never been so free...

Higher productivity

Do you demand maximum productivity from your machine?
With up to 200% more torque and 100% higher speeds than comparable products, the **SK+** offers the optimum performance for maximum output.

In addition, the **SPK+** brings extra torque for higher ratios.

Simple and convenient

From optimised designs with our **cymex**® software through to the classic, patented **alpha** motor mounting system to the identical oil flow rate for all versions, the **SK+/SPK+** pulls out all the stops to make your job as easy as possible.



SK+

Cutting edge innovations – made by alpha

We have been developing, manufacturing and distributing low-backlash planetary gearheads, servo right-angled gearheads, complete drive units and planetary elevator machines with an integrated servo motor since 1984.

Profit from our comprehensive service package: from individual components to complete systems, supported by our competent engineering services. Nearly thousand employees worldwide get involved with offering this service to you. alpha's headquarters are on the "Romantic Road" in Igersheim / Germany.

alpha is a member of the **WITTENSTEIN AG** Group which has rightly established a name for itself with numerous innovations in industries such as aerospace and simulation, medical technology, elevator drives and Formula One racing.

Extraordinarily robust

The **SK+/SPK+** is extremely reliable thanks to its ultra-rugged overall design and 100 % alpha inspection – "fit it and forget it". And with integrated thermal length compensation, the **SK+/SPK+** also maximises the service life of your servomotor in high-speed continuous duty.

Compact and totally flexible

A right-angle drive with the **SK+/SPK+** makes your machine more compact. With reduction ratios from $i = 3$ to $i = 100$ (**SK+**) and $i = 12$ to $i = 100$ (**SPK+**) there are interesting opportunities for practically all designs – always with the classic SP output, the industry standard from alpha.

Reliable and precise

The low torsional backlash and high torsional stiffness of the **SK+/SPK+** assure the positioning accuracy of your drives and the precision of your machines, thanks to the endurance-strength alpha gearing technologies.



SPK+

Leaders of the pack

We are driven by a desire to enhance our customers' success with products and systems from alpha. We set benchmarks when it comes to precision, performance and durability. Our trailblazing technology gives our customers an edge in their respective market sectors. Place your trust in premium quality and total reliability from alpha. Choose world class engineering – the foundation for strong partnerships and added value that is passed on to your customers.

alpha benefits at a glance:

- **Record-breaking lifespan**
Extremely long service life resulting from intelligent design, latest synthetic lubrication technology, exclusive sealing technology, and incredibly strong output bearings.
- **Motor mounting is almost foolproof**
Simple and reliable mounting in a single step.
- **Top quality from alpha**
In-house development and manufacture of all products combined with a pioneering spirit and an insatiable urge to improve.



alpha

1-stage

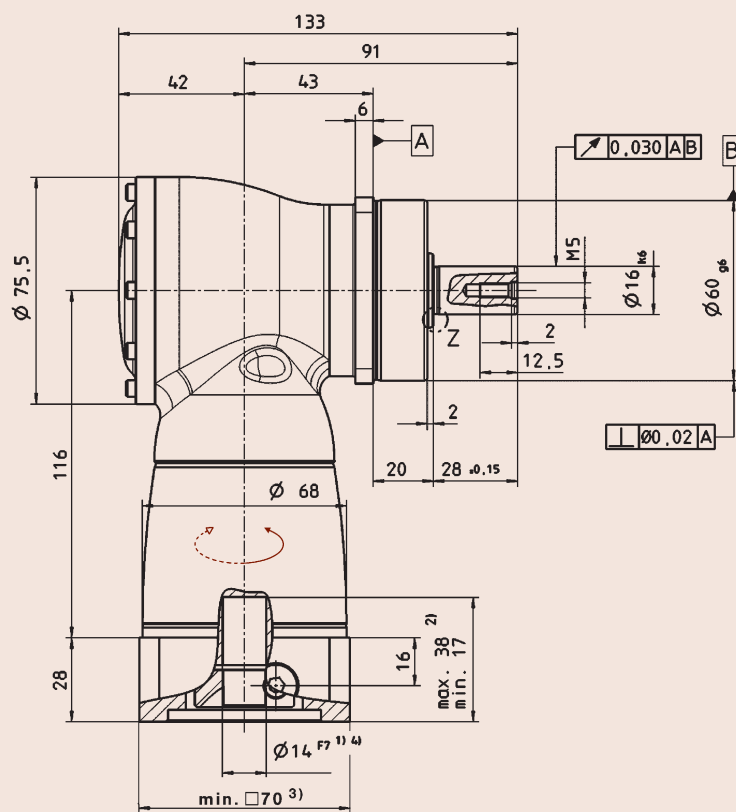
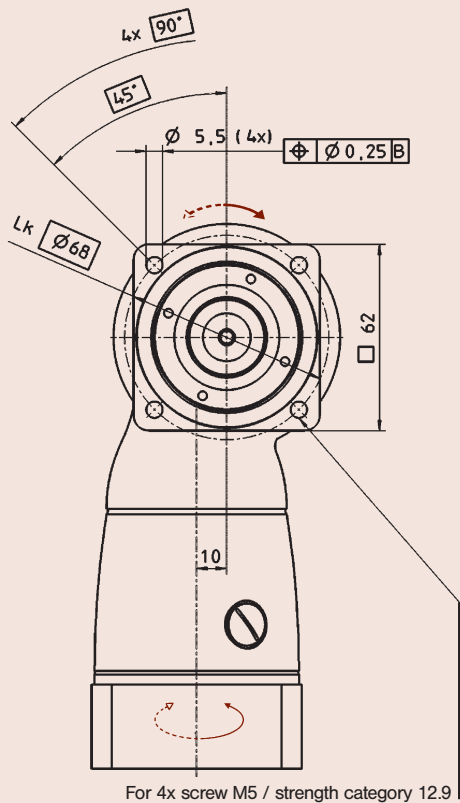

2-stage

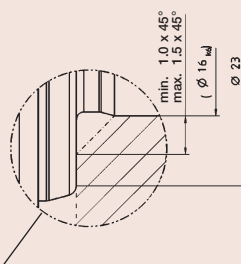

Z: Connecting part

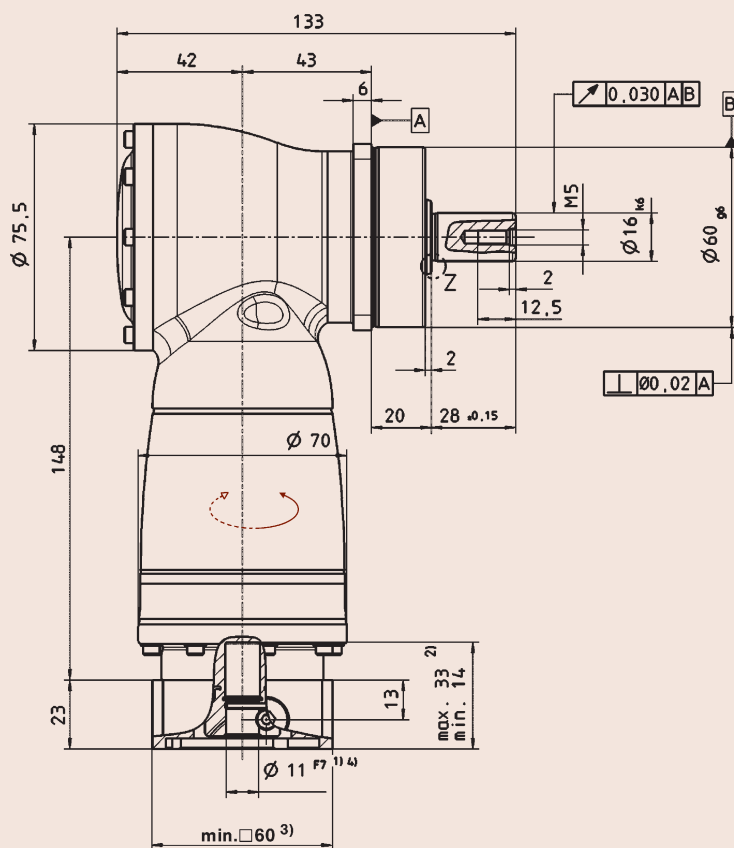

Non-toleranced dimensions ± 1 mm

1) Check motor shaft fit.

2) Min./max. permissible motor shaft length. Longer motor shafts are possible on request: please contact alpha.

3) Dimensions depend on motor.

4) Smaller motor shaft diameters possible using a bushing with a minimum wall thickness of 1 mm (see page 26).

▲ Motor mounting in accordance with Operating Manual.

Technical Data SK+ 060

			1-stage					2-stage									
Ratio	i		3	4	5	7	10	12	16	20	25	28	35	40	50	70	100
Max. acceleration torque (max. 1000 cycles per hour)	T_{2B}	Nm	30	30	30	25	20	30	30	30	30	30	30	30	30	25	20
Nominal output torque	T_{2N}	Nm	22	22	22	20	15	22	22	22	22	22	22	22	22	20	15
Emergency stop torque (Permissible 1000 times during the lifespan of the gearhead)	T_{2Not}	Nm	40	50	50	45	40	50	50	50	50	50	50	50	50	45	40
Nominal input speed at T_{2N} * (At 20 °C ambient temperature) **	n_{1N}	min ⁻¹	2500	2700	3000	3000	3000	4400	4400	4400	4400	4400	4400	4400	4800	5500	5500
Max. continuous speed (At 20 °C ambient temperature and 20% T_{2N}) **	$n_{1N,oyM}$	min ⁻¹	3000	3500	4000	3500	3500	For higher mean speeds, contact alpha									
No-load running torque ($n_1=3000$ rpm) *** (At 20 °C gearhead temperature)	T_{012}	Nm	1.2	1.1	1.0	1.2	1.1	0.2	0.2	0.2	0.2	0.2	0.2	0.1	0.1	0.1	0.1
Max. input speed	n_{1Max}	min ⁻¹	6000	6000	6000	6000	6000	6000	6000	6000	6000	6000	6000	6000	6000	6000	6000
Torsional backlash	j_t	arcmin	≤ 5														
Torsional stiffness	C_{t21}	Nm/arcmin	2.0	2.1	2.2	2.0	1.8	2.1	2.1	2.1	2.1	2.1	2.1	2.1	2.2	2.0	1.8
Max. axial force ****	F_{2AMax}	N	2400														
Max. radial force ****	F_{2RMMax}	N	2700														
Max. tilting moment	M_{2KMMax}	Nm	251														
Efficiency at full load	η	%	96					94									
Service life (see alpha's "Technical Basics" catalogue for calculation)	L_h	h	≥ 20,000														
Weight (incl. ADP)	m	kg	2.9					3.2									
Noise level ($n_1=3000$ min ⁻¹) *****	L_{PA}	dB(A)	≤ 64														
Max. permissible housing temperature		°C	+90														
Ambient temperature		°C	0 to +40														
Lubrication			Synthetic gear oil														
Paint			Blue RAL 5002														
Direction of rotation			Input and output sides in opposite directions														
Type of protection			IP 65														
Mass moment of inertia (referring to the drive)	J_1	kgcm ²	0.52	0.44	0.40	0.36	0.34	0.09	0.09	0.07	0.07	0.06	0.06	0.06	0.06	0.06	0.06

- * Higher mean speeds are possible at reduced nominal torque.
- ** Please reduce the speed at higher ambient temperatures.
- *** The no-load running torque is reduced in operation.
- **** In reference to the centre of the output shaft.
- ***** Measured at ratio $i = 5$.

Alternatives: Output shaft version

Keywayed output shaft in mm

E = Key to DIN 6885, Sheet 1, Form A

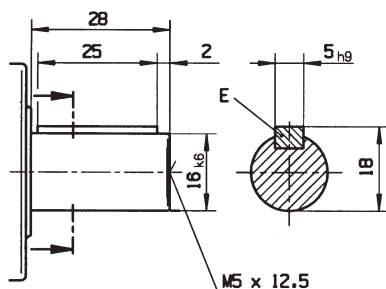

Involute according to DIN 5480
optionally available.

Please contact alpha for optimal
sizing at S1 operating conditions
(continuous duty).

Conversion table

1 mm	= 0.039 in
1 Nm	= 8.85 in.lb
1 kgcm ²	= 8.85 x 10 ⁻⁴ in.lb.s ²
1 N	= 0.225 lb _f
1 kg	= 2.21 lb _m

1-stage

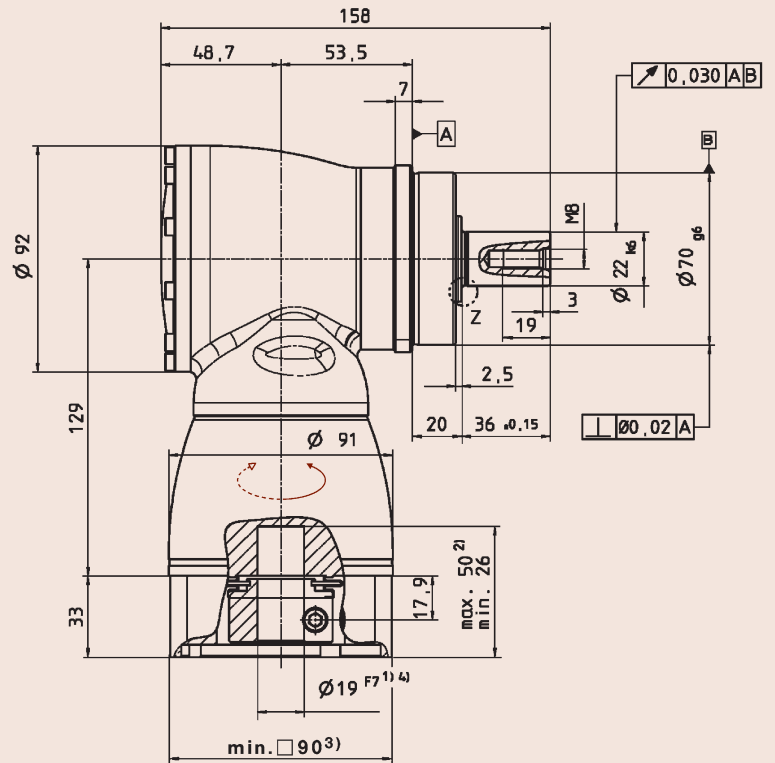
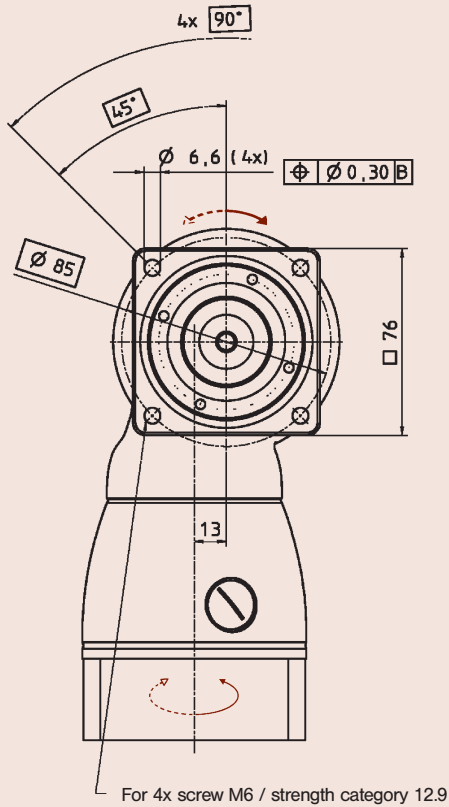

2-stage

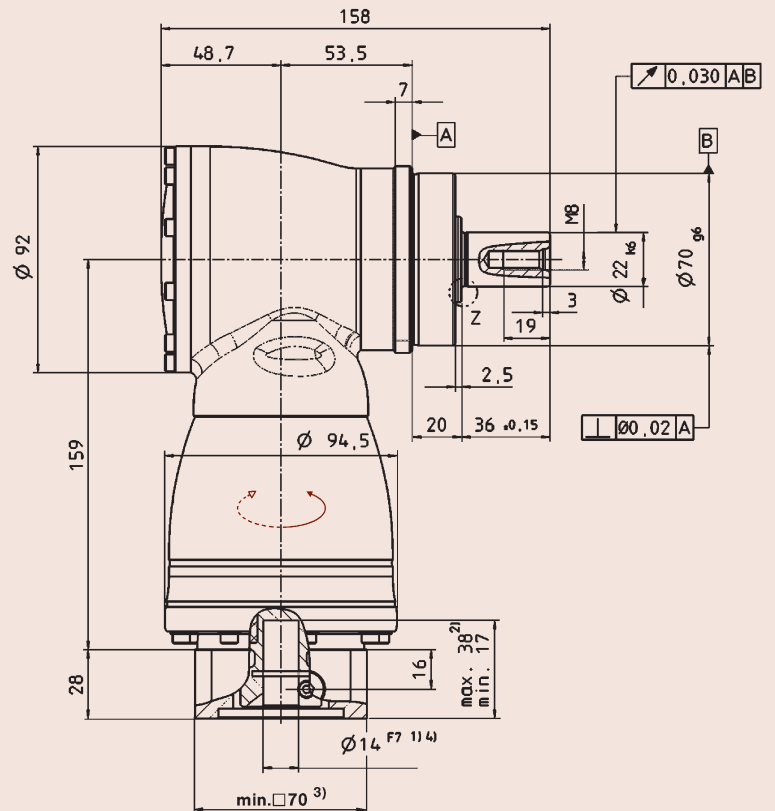
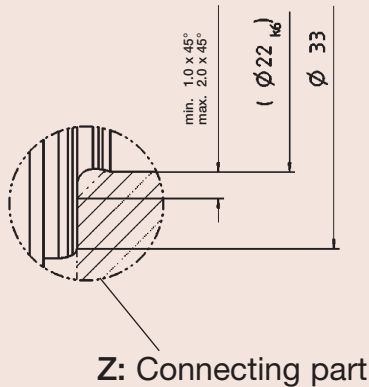

Non-toleranced dimensions ± 1 mm

1) Check motor shaft fit.

2) Min./max. permissible motor shaft length. Longer motor shafts are possible on request: please contact alpha.

3) Dimensions depend on motor.

4) Smaller motor shaft diameters possible using a bushing with a minimum wall thickness of 1 mm (see page 26).

⚠ Motor mounting in accordance with Operating Manual.

Technical Data SK⁺ 075

			1-stage					2-stage									
Ratio	i		3	4	5	7	10	12	16	20	25	28	35	40	50	70	100
Max. acceleration torque (max. 1000 cycles per hour)	T_{2B}	Nm	70	70	70	60	50	70	70	70	70	70	70	70	70	60	50
Nominal output torque	T_{2N}	Nm	50	50	50	45	40	50	50	50	50	50	50	50	50	45	40
Emergency stop torque (Permissible 1000 times during the lifespan of the gearhead)	T_{2Not}	Nm	95	115	115	110	100	115	115	115	115	115	115	115	115	110	100
Nominal input speed at T_{2N} * (At 20 °C ambient temperature) **	n_{1N}	min ⁻¹	2300	2500	2800	2800	2800	3500	3500	3500	3500	3500	3500	3500	3800	4500	4500
Max. continuous speed (At 20 °C ambient temperature and 20% T_{2N}) **	$n_{1N,oyM}$	min ⁻¹	3000	3500	4000	3500	3500	For higher mean speeds, contact alpha									
No-load running torque ($n_1=3000$ rpm) *** (At 20 °C gearhead temperature)	T_{012}	Nm	2.0	1.7	1.5	2.0	1.8	0.3	0.3	0.2	0.2	0.2	0.2	0.1	0.1	0.1	0.1
Max. input speed	n_{1Max}	min ⁻¹	6000	6000	6000	6000	6000	6000	6000	6000	6000	6000	6000	6000	6000	6000	6000
Torsional backlash	j_t	arcmin	≤ 4														
Torsional stiffness	C_{t21}	Nm/arcmin	5.0	5.5	6.0	6.0	6.0	5.5	5.5	5.5	5.5	5.5	5.5	5.5	6.0	6.0	6.0
Max. axial force ****	F_{2AMax}	N	3400														
Max. radial force ****	F_{2RMMax}	N	4000														
Max. tilting moment	M_{2KMMax}	Nm	437														
Efficiency at full load	η	%	96					94									
Service life (see alpha's "Technical Basics" catalogue for calculation)	L_h	h	≥ 20,000														
Weight (incl. ADP)	m	kg	4.8					5.4									
Noise level ($n_1=3000$ min ⁻¹) *****	L_{PA}	dB(A)	≤ 66														
Max. permissible housing temperature		°C	+90														
Ambient temperature		°C	0 to +40														
Lubrication			Synthetic gear oil														
Paint			Blue RAL 5002														
Direction of rotation			Input and output sides in opposite directions														
Type of protection			IP 65														
Mass moment of inertia (referring to the drive)	J_1	kgcm ²	1.46	1.19	1.06	0.95	0.90	0.29	0.27	0.23	0.23	0.20	0.20	0.18	0.18	0.18	0.18

- * Higher mean speeds are possible at reduced nominal torque.
- ** Please reduce the speed at higher ambient temperatures.
- *** The no-load running torque is reduced in operation.
- **** In reference to the centre of the output shaft.
- ***** Measured at ratio $i = 5$.

Alternatives: Output shaft version

Keywayed output shaft in mm

E = Key to DIN 6885, Sheet 1, Form A

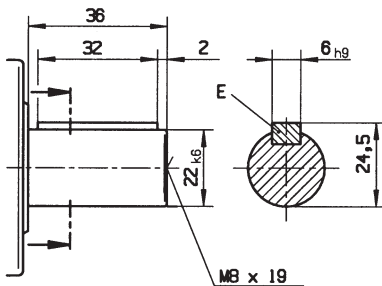

Involute according to DIN 5480
optionally available.

Please contact alpha for optimal sizing at S1 operating conditions (continuous duty).

Conversion table

1 mm	= 0.039 in
1 Nm	= 8.85 in.lb
1 kgcm ²	= 8.85 x 10 ⁻⁴ in.lb.s ²
1 N	= 0.225 lb _f
1 kg	= 2.21 lb _m

1-stage

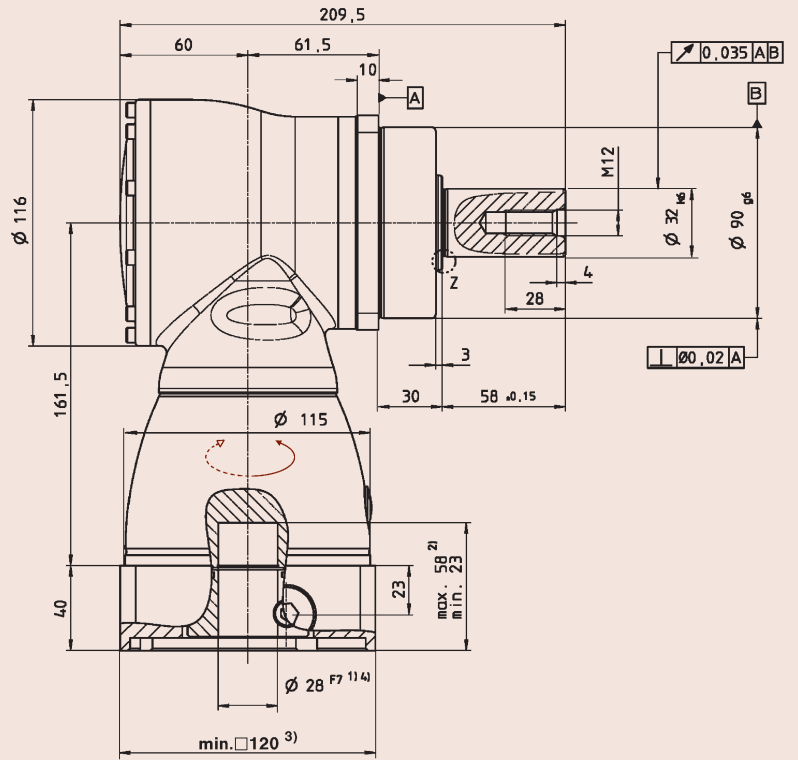
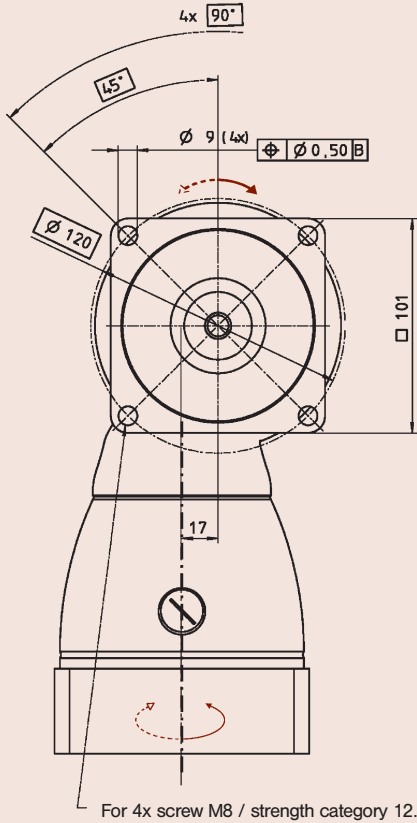

2-stage

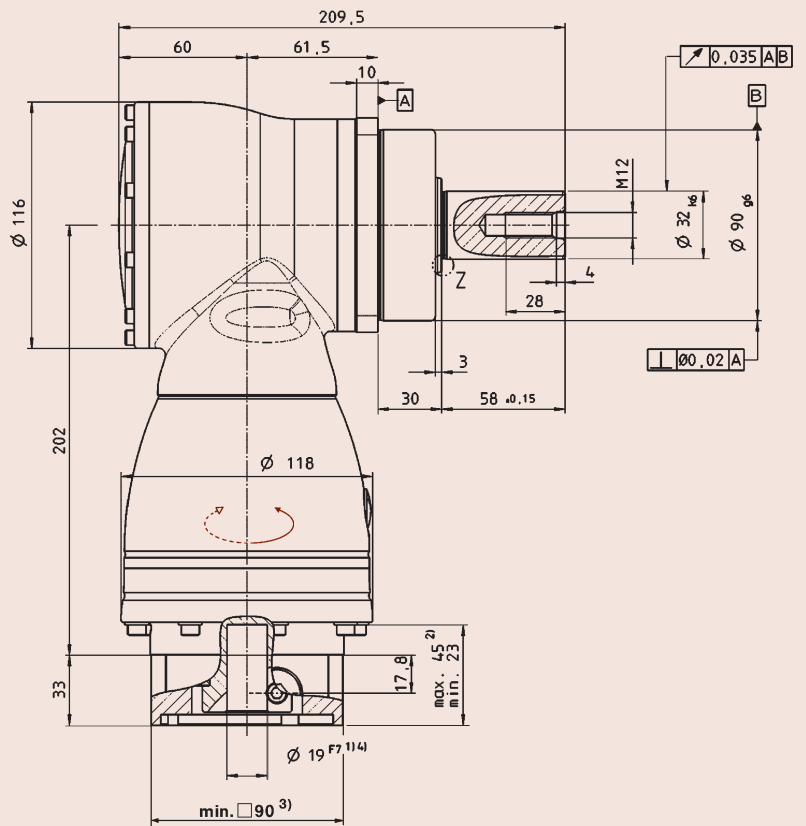
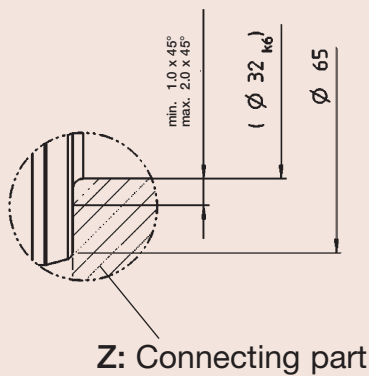

Non-toleranced dimensions ± 1 mm

1) Check motor shaft fit.

2) Min./max. permissible motor shaft length. Longer motor shafts are possible on request: please contact alpha.

3) Dimensions depend on motor.

4) Smaller motor shaft diameters possible using a bushing with a minimum wall thickness of 1 mm (see page 26).

⚠ Motor mounting in accordance with Operating Manual.

Technical Data SK+ 100

			1-stage					2-stage									
Ratio	i		3	4	5	7	10	12	16	20	25	28	35	40	50	70	100
Max. acceleration torque (max. 1000 cycles per hour)	T_{2B}	Nm	170	170	170	145	125	170	170	170	170	170	170	170	170	145	125
Nominal output torque	T_{2N}	Nm	100	100	100	90	80	100	100	100	100	100	100	100	100	90	80
Emergency stop torque (Permissible 1000 times during the lifespan of the gearhead)	T_{2Not}	Nm	220	260	260	255	250	260	260	260	260	260	260	260	260	255	250
Nominal input speed at T_{2N} * (At 20 °C ambient temperature) **	n_{1N}	min ⁻¹	2200	2400	2700	2500	2500	3100	3100	3100	3100	3100	3100	3100	3500	4200	4200
Max. continuous speed (At 20 °C ambient temperature and 20% T_{2N}) **	$n_{1N,oyM}$	min ⁻¹	3000	3400	3800	3400	3400	For higher mean speeds, contact alpha									
No-load running torque ($n_1=3000$ rpm) *** (At 20 °C gearhead temperature)	T_{012}	Nm	3.8	3.0	2.3	3.5	2.8	0.6	0.6	0.5	0.4	0.4	0.3	0.2	0.2	0.2	0.2
Max. input speed	n_{1Max}	min ⁻¹	4500	4500	4500	4500	4500	4500	4500	4500	4500	4500	4500	4500	4500	4500	4500
Torsional backlash	j_t	arcmin	≤ 4														
Torsional stiffness	C_{t21}	Nm/arcmin	10	11	13	13	13	11	11	11	11	11	11	11	13	13	13
Max. axial force ****	F_{2AMax}	N	5700														
Max. radial force ****	F_{2RMMax}	N	6300														
Max. tilting moment	M_{2KMMax}	Nm	833														
Efficiency at full load	η	%	96					94									
Service life (see alpha's "Technical Basics" catalogue for calculation)	L_h	h	≥ 20,000														
Weight (incl. ADP)	m	kg	9.3					10.0									
Noise level ($n_1=3000$ min ⁻¹) *****	L_{PA}	dB(A)	≤ 66														
Max. permissible housing temperature		°C	+90														
Ambient temperature		°C	0 to +40														
Lubrication			Synthetic gear oil														
Paint			Blue RAL 5002														
Direction of rotation			Input and output sides in opposite directions														
Type of protection			IP 65														
Mass moment of inertia (referring to the drive)	J_1	kgcm ²	4.64	3.80	3.34	2.98	2.79	1.03	0.98	0.86	0.84	0.75	0.74	0.69	0.69	0.68	0.68

- * Higher mean speeds are possible at reduced nominal torque.
- ** Please reduce the speed at higher ambient temperatures.
- *** The no-load running torque is reduced in operation.
- **** In reference to the centre of the output shaft.
- ***** Measured at ratio $i = 5$.

Alternatives: Output shaft version

Keywayed output shaft in mm

E = Key to DIN 6885, Sheet 1, Form A

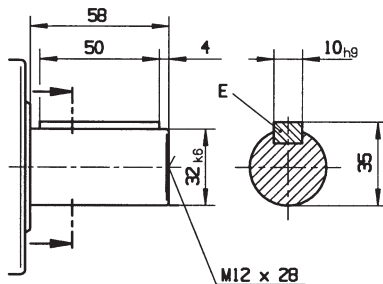

Involute according to DIN 5480
optionally available.

Please contact alpha for optimal
sizing at S1 operating conditions
(continuous duty).

Conversion table

1 mm	= 0.039 in
1 Nm	= 8.85 in.lb
1 kgcm ²	= 8.85 x 10 ⁻⁴ in.lb.s ²
1 N	= 0.225 lb _f
1 kg	= 2.21 lb _m

1-stage

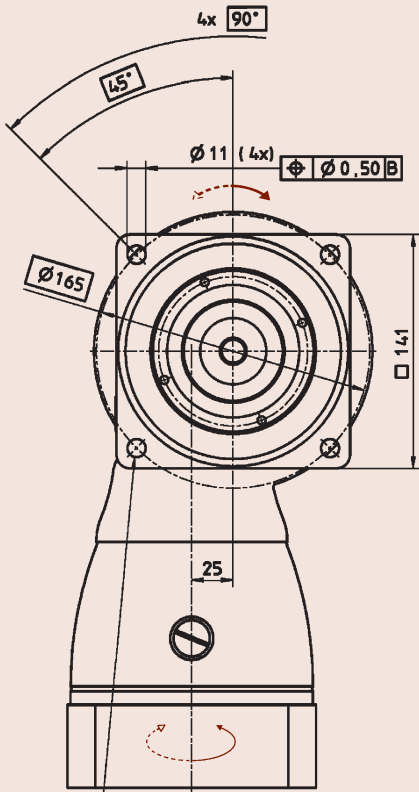

For 4x screw M10 / strength category 12.9

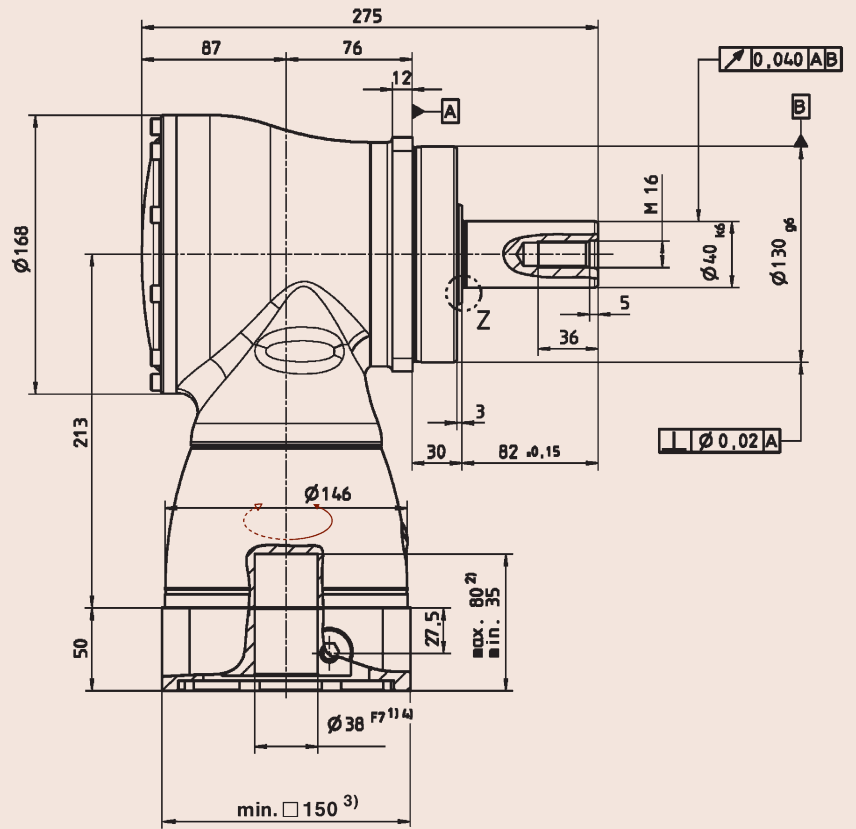

2-stage

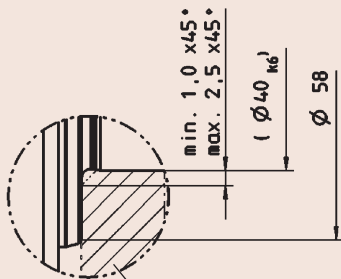

Z: Connecting part

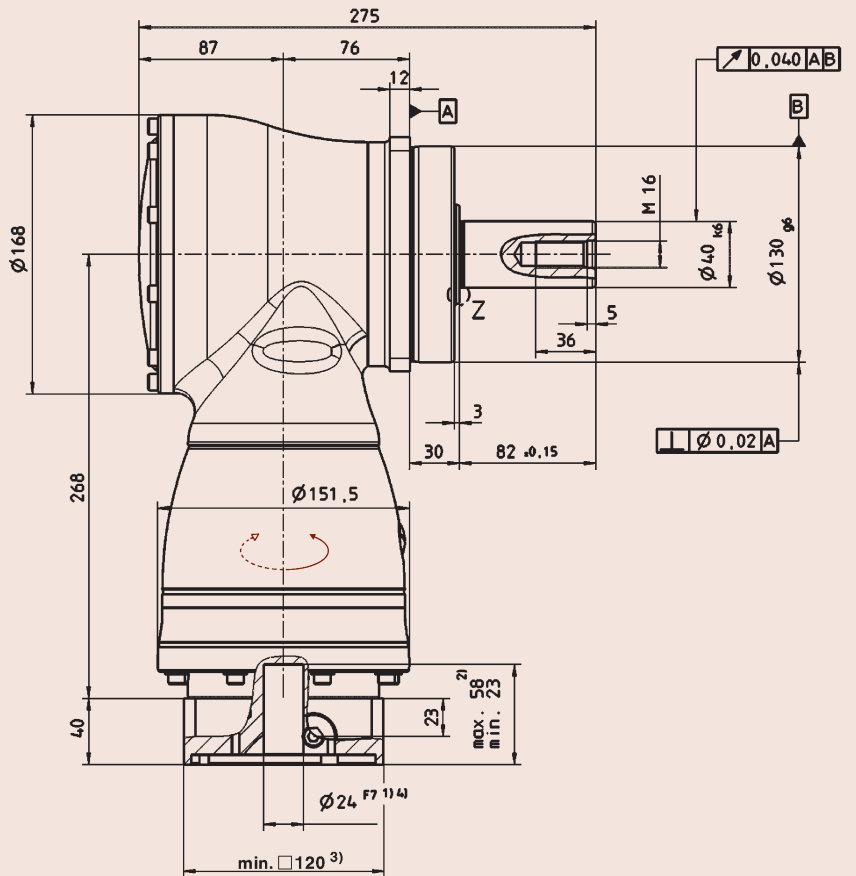

Non-toleranced dimensions ± 1 mm

1) Check motor shaft fit.

2) Min./max. permissible motor shaft length. Longer motor shafts are possible on request: please contact alpha.

3) Dimensions depend on motor.

4) Smaller motor shaft diameters possible using a bushing with a minimum wall thickness of 1 mm (see page 26).

▲ Motor mounting in accordance with Operating Manual.

Technical Data SK⁺ 140

			1-stage					2-stage									
Ratio	i		3	4	5	7	10	12	16	20	25	28	35	40	50	70	100
Max. acceleration torque (max. 1000 cycles per hour)	T_{2B}	Nm	300	300	300	250	210	300	300	300	300	300	300	300	300	250	210
Nominal output torque	T_{2N}	Nm	190	190	190	175	160	190	190	190	190	190	190	190	190	175	160
Emergency stop torque (Permissible 1000 times during the lifespan of the gearhead)	T_{2Not}	Nm	400	500	500	450	400	500	500	500	500	500	500	500	500	450	400
Nominal input speed at T_{2N} * (At 20 °C ambient temperature) **	n_{1N}	min ⁻¹	1900	2000	2200	2000	2000	2900	2900	2900	2900	2900	2900	2900	3200	3200	3900
Max. continuous speed (At 20 °C ambient temperature and 20% T_{2N}) **	$n_{1N,oyM}$	min ⁻¹	2500	2800	3100	2800	2800	For higher mean speeds, contact alpha									
No-load running torque ($n_1=3000$ rpm) *** (At 20 °C gearhead temperature)	T_{012}	Nm	7.0	5.2	4.5	7.5	5.5	1.4	0.9	0.7	0.5	0.5	0.4	0.4	0.3	0.3	0.3
Max. input speed	n_{1Max}	min ⁻¹	4500	4500	4500	4500	4500	4500	4500	4500	4500	4500	4500	4500	4500	4500	4500
Torsional backlash	j_t	arcmin	≤ 4														
Torsional stiffness	C_{t21}	Nm/arcmin	27	30	32	32	32	29	29	29	29	29	29	29	31	31	31
Max. axial force ****	F_{2AMax}	N	9900														
Max. radial force ****	F_{2RMMax}	N	9500														
Max. tilting moment	M_{2KMMax}	Nm	1692														
Efficiency at full load	η	%	96					94									
Service life (see alpha's "Technical Basics" catalogue for calculation)	L_h	h	≥ 20,000														
Weight (incl. ADP)	m	kg	22.6					25.0									
Noise level ($n_1=3000$ min ⁻¹) *****	L_{PA}	dB(A)	≤ 68														
Max. permissible housing temperature		°C	+90														
Ambient temperature		°C	0 to +40														
Lubrication			Synthetic gear oil														
Paint			Blue RAL 5002														
Direction of rotation			Input and output sides in opposite directions														
Type of protection			IP 65														
Mass moment of inertia (referring to the drive)	J_1	kgcm ²	25.0	19.1	16.3	14.1	12.8	4.2	3.9	3.3	3.2	2.8	2.7	2.5	2.5	2.4	2.4

- * Higher mean speeds are possible at reduced nominal torque.
- ** Please reduce the speed at higher ambient temperatures.
- *** The no-load running torque is reduced in operation.
- **** In reference to the centre of the output shaft.
- ***** Measured at ratio $i = 5$.

Alternatives: Output shaft version

Keywayed output shaft in mm

E = Key to DIN 6885, Sheet 1, Form A

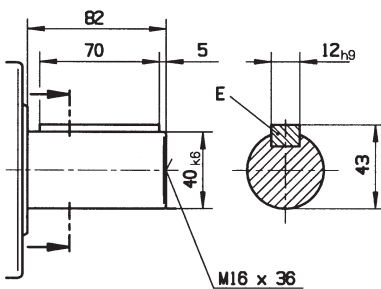

Involute according to DIN 5480 optionally available.

Please contact alpha for optimal sizing at S1 operating conditions (continuous duty).

Conversion table

1 mm	= 0.039 in
1 Nm	= 8.85 in.lb
1 kgcm ²	= 8.85 x 10 ⁻⁴ in.lb.s ²
1 N	= 0.225 lb _f
1 kg	= 2.21 lb _m

1-stage

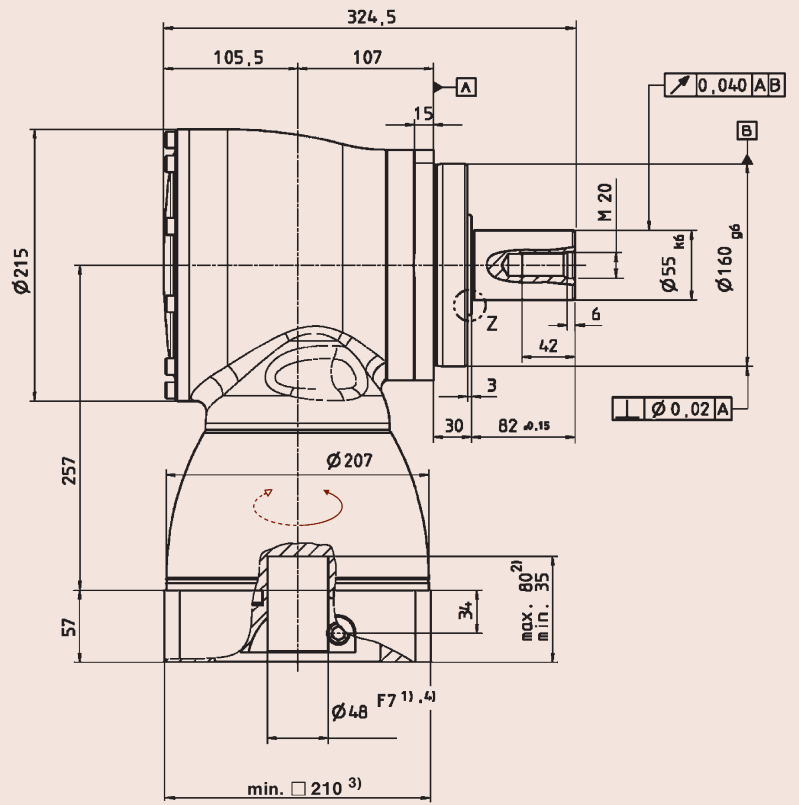
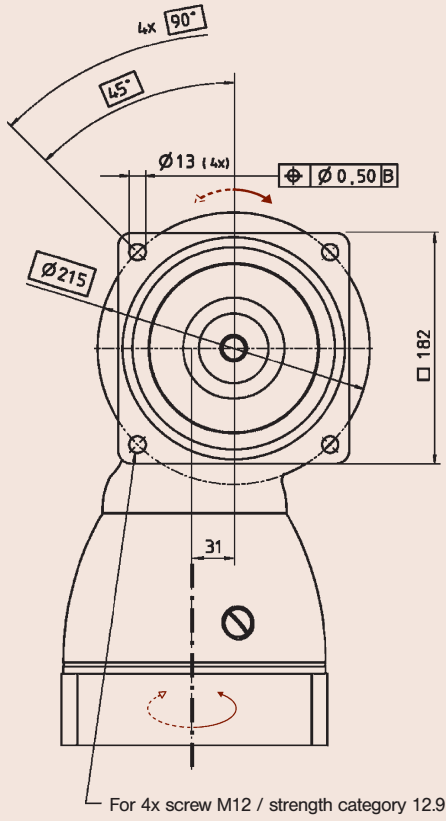

2-stage

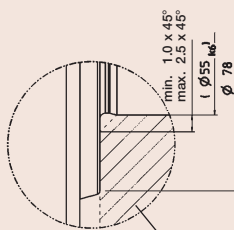

Z: Connecting part

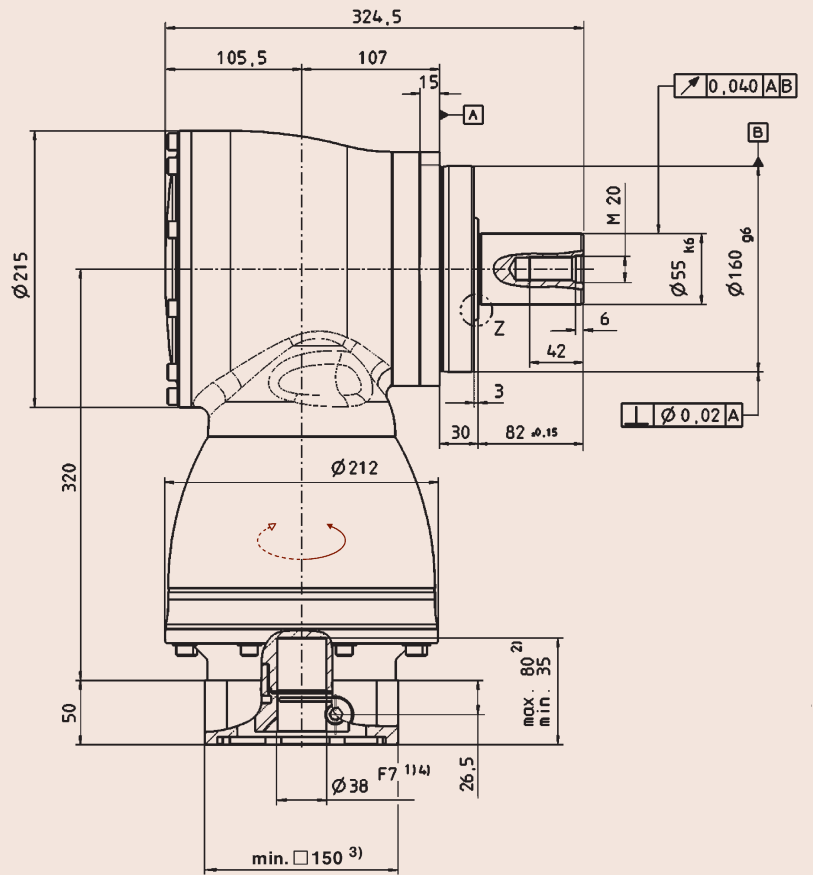

Non-toleranced dimensions ± 1 mm

1) Check motor shaft fit.

2) Min./max. permissible motor shaft length. Longer motor shafts are possible on request: please contact alpha.

3) Dimensions depend on motor.

4) Smaller motor shaft diameters possible using a bushing with a minimum wall thickness of 1 mm (see page 26).

▲ Motor mounting in accordance with Operating Manual.

Technical Data SK+ 180

			1-stage					2-stage									
Ratio	i		3	4	5	7	10	12	16	20	25	28	35	40	50	70	100
Max. acceleration torque (max. 1000 cycles per hour)	T_{2B}	Nm	640	640	640	550	470	640	640	640	640	640	640	640	640	550	470
Nominal output torque	T_{2N}	Nm	400	400	400	380	360	400	400	400	400	400	400	400	400	380	360
Emergency stop torque (Permissible 1000 times during the lifespan of the gearhead)	T_{2Not}	Nm	900	1050	1050	970	900	1050	1050	1050	1050	1050	1050	1050	1050	970	900
Nominal input speed at T_{2N} * (At 20 °C ambient temperature) **	n_{1N}	min ⁻¹	1600	1800	2000	1800	1800	2700	2700	2700	2700	2700	2700	2700	2900	3200	3400
Max. continuous speed (At 20 °C ambient temperature and 20% T_{2N}) **	$n_{1N,oyM}$	min ⁻¹	2000	2400	2800	2500	2500	For higher mean speeds, contact alpha									
No-load running torque ($n_1=3000$ rpm) *** (At 20 °C gearhead temperature)	T_{012}	Nm	14.5	12.0	10.0	15.0	12.5	3.0	2.3	1.8	1.6	1.3	1.2	0.9	0.9	0.9	0.9
Max. input speed	n_{1Max}	min ⁻¹	4000	4000	4000	4000	4000	4000	4000	4000	4000	4000	4000	4000	4000	4000	4000
Torsional backlash	j_t	arcmin	≤ 4														
Torsional stiffness	C_{t21}	Nm/arcmin	64	71	79	78	77	71	71	71	71	71	71	71	78	78	78
Max. axial force ****	F_{2AMax}	N	14200														
Max. radial force ****	F_{2RMMax}	N	14700														
Max. tilting moment	M_{2KMMax}	Nm	3213														
Efficiency at full load	η	%	96					94									
Service life (see alpha's "Technical Basics" catalogue for calculation)	L_h	h	≥ 20,000														
Weight (incl. ADP)	m	kg	45.4					48									
Noise level ($n_1=3000$ min ⁻¹) *****	L_{PA}	dB(A)	≤ 68														
Max. permissible housing temperature		°C	+90														
Ambient temperature		°C	0 to +40														
Lubrication			Synthetic gear oil														
Paint			Blue RAL 5002														
Direction of rotation			Input and output sides in opposite directions														
Type of protection			IP 65														
Mass moment of inertia (referring to the drive)	J_1	kgcm ²	73.3	51.6	42.1	34.0	29.7	15.6	14.0	12.3	12.0	10.9	10.7	10.1	10.0	10.0	9.9

- * Higher mean speeds are possible at reduced nominal torque.
- ** Please reduce the speed at higher ambient temperatures.
- *** The no-load running torque is reduced in operation.
- **** In reference to the centre of the output shaft.
- ***** Measured at ratio $i = 5$.

Alternatives: Output shaft version

Keywayed output shaft in mm

E = Key to DIN 6885, Sheet 1, Form A

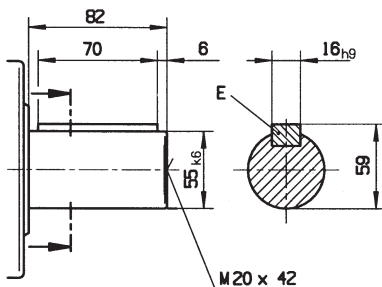

Involute according to DIN 5480 optionally available.

Please contact alpha for optimal sizing at S1 operating conditions (continuous duty).

Conversion table

1 mm	= 0.039 in
1 Nm	= 8.85 in.lb
1 kgcm ²	= 8.85 x 10 ⁻⁴ in.lb.s ²
1 N	= 0.225 lb _f
1 kg	= 2.21 lb _m

2-stage

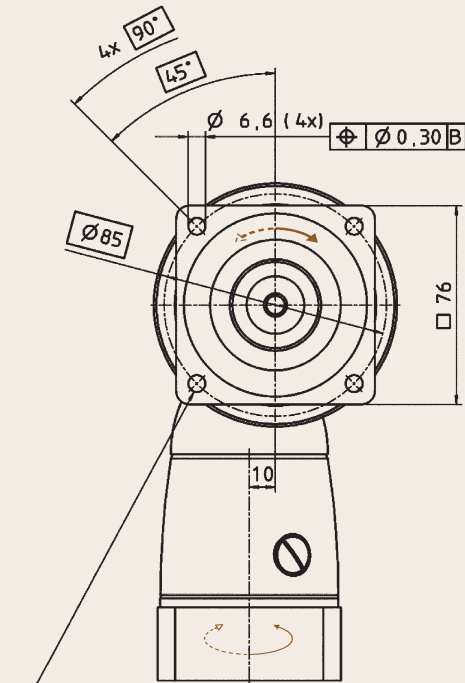

For 4x screw M6 / strength category 12.9

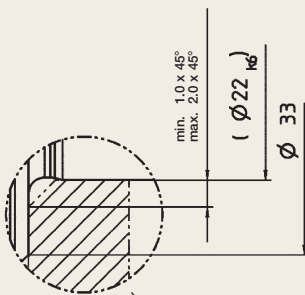
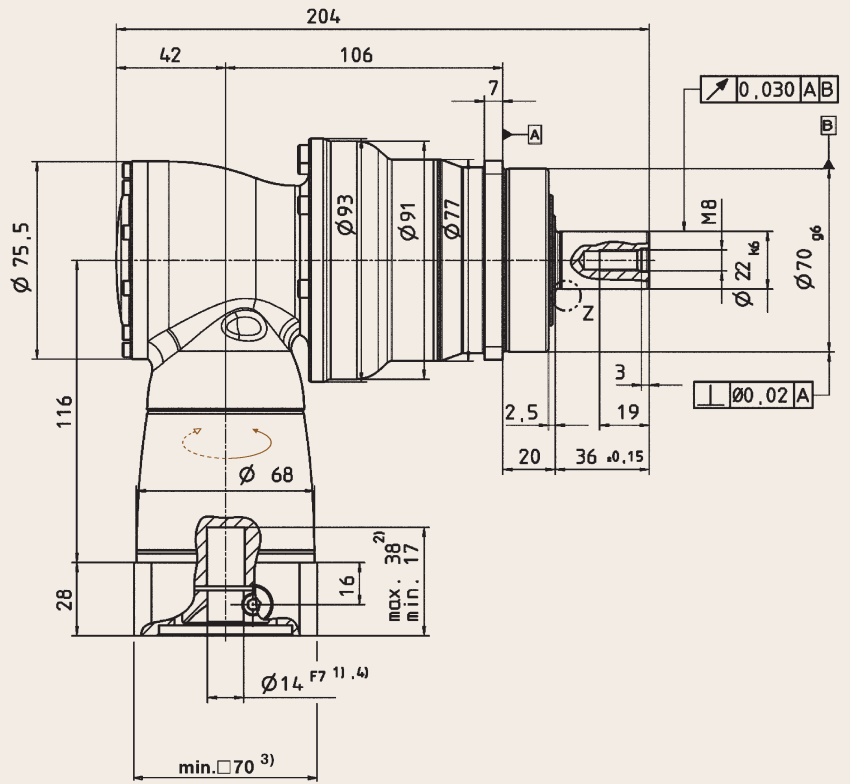

Z: Connecting part

Non-toleranced dimensions ±1 mm

1) Check motor shaft fit.

2) Min./max. permissible motor shaft length. Longer motor shafts are possible on request: please contact alpha.

3) Dimensions depend on motor.

4) Smaller motor shaft diameters possible using a bushing with a minimum wall thickness of 1 mm (see page 26).

⚠ Motor mounting in accordance with Operating Manual.

Technical Data SPK+ 075 2-stage

			2-stage									
Ratio *	i		12	16	20	25	28	35	40	50	70	100
Max. acceleration torque (max. 1000 cycles per hour)	T_{2B}	Nm	110	110	110	110	110	110	80	100	110	90
Nominal output torque	T_{2N}	Nm	75	75	75	75	75	75	60	75	75	52
Emergency stop torque (Permissible 1000 times during the lifespan of the gearhead)	T_{2Not}	Nm	160	160	200	200	250	175	120	150	210	200
Nominal input speed at T_{2N} ** (At 20 °C ambient temperature) ***	n_{1N}	min ⁻¹	2000	2400	2400	2700	2400	2500	2500	2500	2500	2500
Max. continuous speed (At 20 °C ambient temperature and 20% T_{2N}) ***	$n_{1N,cym}$	min ⁻¹	3000	3400	3400	3800	3400	3200	3200	3200	3200	3200
No-load running torque ($n_1=3000$ rpm) **** (At 20 °C gearhead temperature)	T_{012}	Nm	1.5	1.3	1.2	1.2	1.2	1.3	1.3	1.3	1.3	1.3
Max. input speed	n_{1Max}	min ⁻¹	6000	6000	6000	6000	6000	6000	6000	6000	6000	6000
Torsional backlash	j_t	arcmin	Standard ≤ 6 / Reduced ≤ 4									
Torsional stiffness	C_{t21}	Nm/arcmin	10									
Max. axial force ****	F_{2AMax}	N	3350									
Max. radial force *****	F_{2RMMax}	N	4000									
Max. tilting moment	M_{2KMMax}	Nm	236									
Efficiency at full load	η	%	94									
Service life (see alpha's "Technical Basics" catalogue for calculation)	L_h	h	$\geq 20,000$									
Weight (incl. ADP)	m	kg	5.2									
Noise level ($n_1=3000$ min ⁻¹) *****	L_{PA}	dB(A)	≤ 66									
Max. permissible housing temperature		°C	+ 90									
Ambient temperature		°C	0 to +40									
Lubrication			Synthetic gear oil									
Paint			Blue RAL 5002									
Direction of rotation			Input and output sides in opposite directions									
Type of protection			IP 65									
Mass moment of inertia (referring to the drive)	J_1	kgcm ²	0.54	0.45	0.44	0.40	0.44	0.36	0.35	0.34	0.34	0.34

- * The binary ratio $i = 32$ is optionally available.
- ** Higher mean speeds are possible at reduced nominal torque.
- *** Please reduce the speed at higher ambient temperatures.
- **** The no-load running torque is reduced in operation.
- ***** In reference to the centre of the output shaft.
- ***** Measured at ratio $i = 40$.

Alternatives: Output shaft version

Keywayed output shaft in mm

E = Key to DIN 6885, Sheet 1, Form A

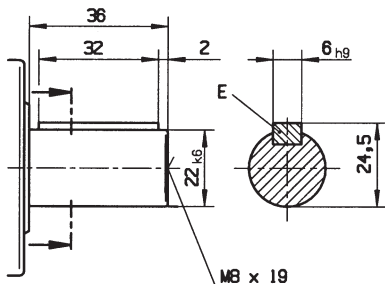

Involute according to DIN 5480 in mm

X = W 22 x 1.25 x 30 x 16 x 6m, DIN 5480

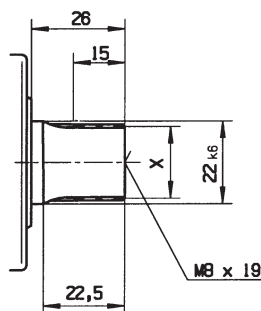

Please contact alpha for optimal sizing at S1 operating conditions (continuous duty).

Conversion table

1 mm	= 0.039 in
1 Nm	= 8.85 in.lb
1 kgcm ²	= 8.85×10^{-4} in.lb.s ²
1 N	= 0.225 lb _f
1 kg	= 2.21 lb _m

2-stage

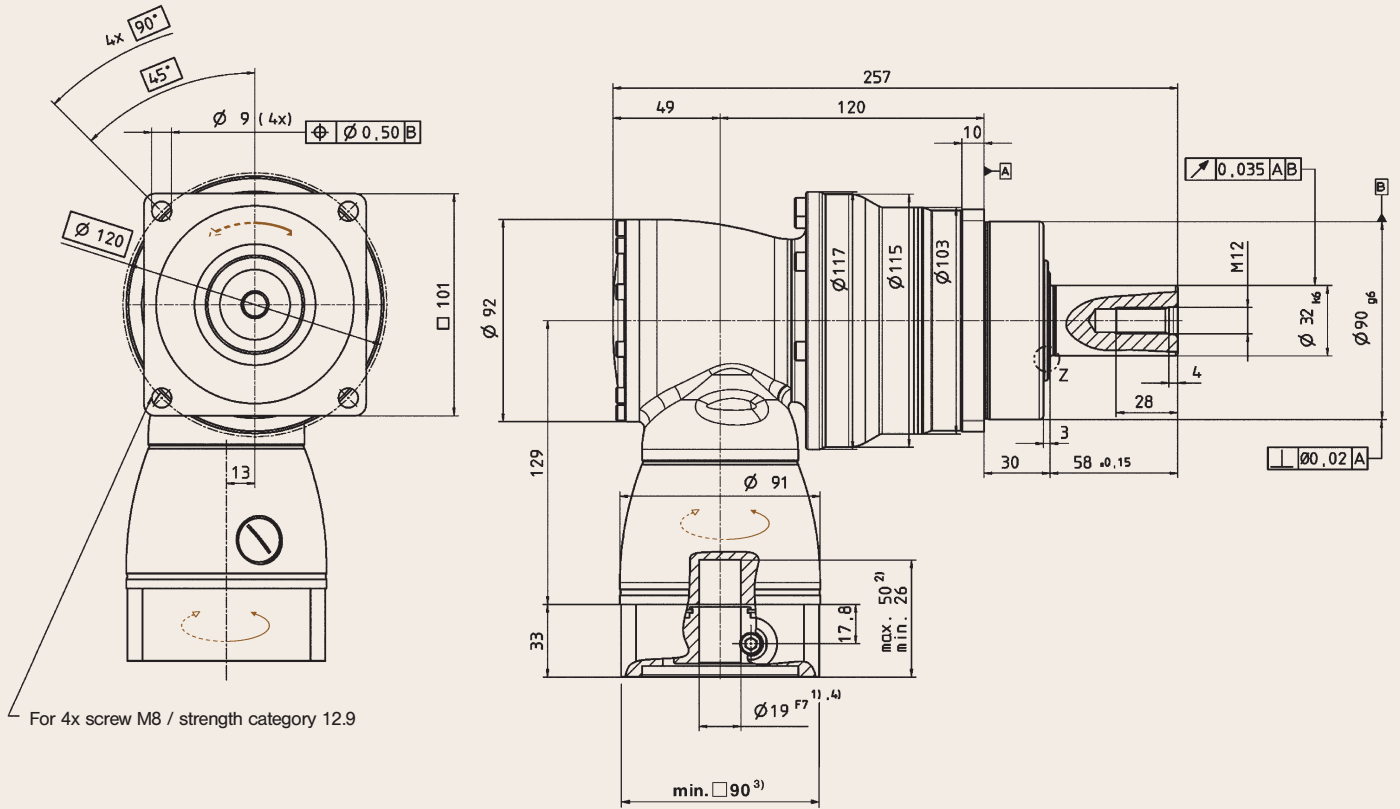

Z: Connecting part

Non-toleranced dimensions ±1 mm

1) Check motor shaft fit.

2) Min./max. permissible motor shaft length. Longer motor shafts are possible on request: please contact alpha.

3) Dimensions depend on motor.

4) Smaller motor shaft diameters possible using a bushing with a minimum wall thickness of 1 mm (see page 26).

⚠ Motor mounting in accordance with Operating Manual.

Technical Data SPK+ 100 2-stage

			2-stage									
Ratio *	i		12	16	20	25	28	35	40	50	70	100
Max. acceleration torque (max. 1000 cycles per hour)	T_{2B}	Nm	280	280	300	300	300	300	200	250	300	225
Nominal output torque	T_{2N}	Nm	180	180	175	175	170	175	160	175	170	120
Emergency stop torque (Permissible 1000 times during the lifespan of the gearhead)	T_{2Not}	Nm	400	400	500	500	625	500	400	500	625	500
Nominal input speed at T_{2N} ** (At 20 °C ambient temperature) ***	n_{1N}	min ⁻¹	2000	2400	2400	2700	2400	2500	2500	2500	2500	2500
Max. continuous speed (At 20 °C ambient temperature and 20% T_{2N}) ***	$n_{1N,cym}$	min ⁻¹	3000	3400	3400	3800	3400	3200	3200	3200	3200	3200
No-load running torque ($n_1=3000$ rpm) **** (At 20 °C gearhead temperature)	T_{012}	Nm	2.5	2.1	2.0	1.8	2.0	2.2	2.0	2.0	2.0	2.0
Max. input speed	n_{1Max}	min ⁻¹	6000	6000	6000	6000	6000	6000	6000	6000	6000	6000
Torsional backlash	j_t	arcmin	Standard ≤ 4 / Reduced ≤ 2									
Torsional stiffness	C_{t21}	Nm/arcmin	31									
Max. axial force ****	F_{2AMax}	N	5650									
Max. radial force *****	F_{2RMMax}	N	6300									
Max. tilting moment	M_{2KMMax}	Nm	487									
Efficiency at full load	η	%	94									
Service life (see alpha's "Technical Basics" catalogue for calculation)	L_h	h	$\geq 20,000$									
Weight (incl. ADP)	m	kg	9.7									
Noise level ($n_1=3000$ min ⁻¹) *****	L_{PA}	dB(A)	≤ 68									
Max. permissible housing temperature		°C	+ 90									
Ambient temperature		°C	0 to +40									
Lubrication			Synthetic gear oil									
Paint			Blue RAL 5002									
Direction of rotation			Input and output sides in opposite directions									
Type of protection			IP 65									
Mass moment of inertia (referring to the drive)	J_1	kgcm ²	1.48	1.20	1.17	1.05	1.15	0.95	0.90	0.89	0.89	0.89

- * The binary ratio $i = 32$ is optionally available.
- ** Higher mean speeds are possible at reduced nominal torque.
- *** Please reduce the speed at higher ambient temperatures.
- **** The no-load running torque is reduced in operation.
- ***** In reference to the centre of the output shaft.
- ***** Measured at ratio $i = 40$.

Alternatives: Output shaft version

Keywayed output shaft in mm

E = Key to DIN 6885, Sheet 1, Form A

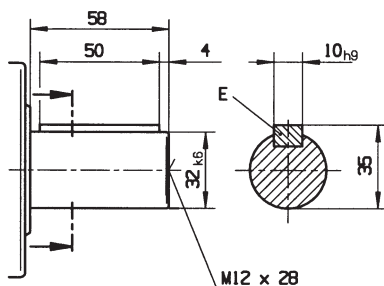

Involute according to DIN 5480 in mm

X = W 32 x 1.25 x 30 x 24 x 6m, DIN 5480

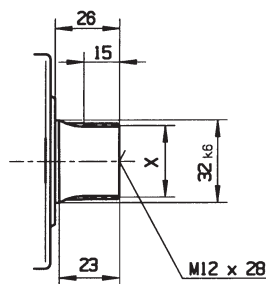

Please contact alpha for optimal sizing at S1 operating conditions (continuous duty).

Conversion table

1 mm	= 0.039 in
1 Nm	= 8.85 in.lb
1 kgcm ²	= 8.85 x 10 ⁻⁴ in.lb.s ²
1 N	= 0.225 lb _f
1 kg	= 2.21 lb _m

2-stage

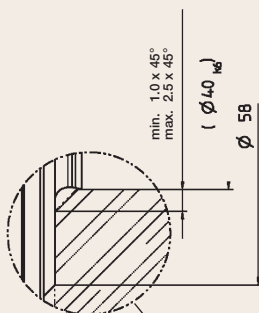
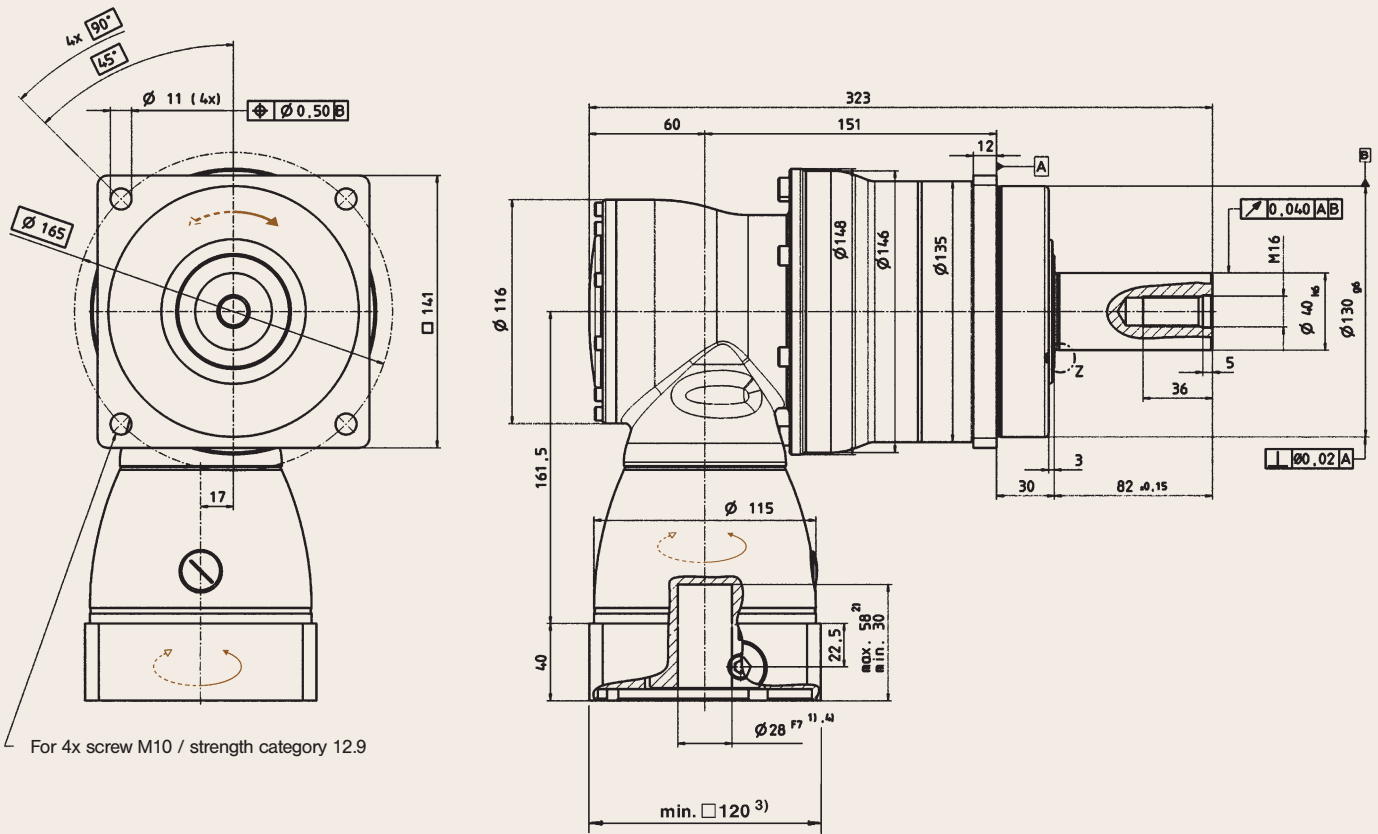

Z: Connecting part

Non-toleranced dimensions ± 1 mm

1) Check motor shaft fit.

2) Min./max. permissible motor shaft length. Longer motor shafts are possible on request: please contact alpha.

3) Dimensions depend on motor.

4) Smaller motor shaft diameters possible using a bushing with a minimum wall thickness of 1 mm (see page 26).

⚠ Motor mounting in accordance with Operating Manual.

Technical Data SPK+ 140 2-stage

			2-stage									
Ratio *	i		12	16	20	25	28	35	40	50	70	100
Max. acceleration torque (max. 1000 cycles per hour)	T_{2B}	Nm	600	600	600	600	600	600	500	600	600	480
Nominal output torque	T_{2N}	Nm	360	360	360	360	360	360	320	360	360	220
Emergency stop torque (Permissible 1000 times during the lifespan of the gearhead)	T_{2Not}	Nm	1000	1000	1250	1250	1250	1250	1000	1250	1250	1000
Nominal input speed at T_{2N} ** (At 20 °C ambient temperature) ***	n_{1N}	min ⁻¹	1900	2300	2300	2600	2300	2300	2300	2300	2300	2300
Max. continuous speed (At 20 °C ambient temperature and 20% T_{2N}) ***	$n_{1N,cym}$	min ⁻¹	2700	3100	3100	3500	3100	3000	3000	3000	3000	3000
No-load running torque ($n_1=3000$ rpm) **** (At 20 °C gearhead temperature)	T_{012}	Nm	4.0	3.7	3.6	2.8	3.5	3.9	3.1	3.1	3.1	3.1
Max. input speed	n_{1Max}	min ⁻¹	4500	4500	4500	4500	4500	4500	4500	4500	4500	4500
Torsional backlash	j_t	arcmin	Standard ≤ 4 / Reduced ≤ 2									
Torsional stiffness	C_{t21}	Nm/arcmin	53									
Max. axial force ****	F_{2AMax}	N	9870									
Max. radial force *****	F_{2RMMax}	N	9450									
Max. tilting moment	M_{2KMMax}	Nm	952									
Efficiency at full load	η	%	94									
Service life (see alpha's "Technical Basics" catalogue for calculation)	L_h	h	$\geq 20,000$									
Weight (incl. ADP)	m	kg	20									
Noise level ($n_1=3000$ min ⁻¹) *****	L_{PA}	dB(A)	≤ 68									
Max. permissible housing temperature		°C	+ 90									
Ambient temperature		°C	0 to +40									
Lubrication			Synthetic gear oil									
Paint			Blue RAL 5002									
Direction of rotation			Input and output sides in opposite directions									
Type of protection			IP 65									
Mass moment of inertia (referring to the drive)	J_1	kgcm ²	4.68	3.82	3.75	3.31	3.68	2.97	2.80	2.79	2.78	2.77

- * The binary ratio $i = 32$ is optionally available.
- ** Higher mean speeds are possible at reduced nominal torque.
- *** Please reduce the speed at higher ambient temperatures.
- **** The no-load running torque is reduced in operation.
- ***** In reference to the centre of the output shaft.
- ***** Measured at ratio $i = 40$.

Alternatives: Output shaft version

Keywayed output shaft in mm

E = Key to DIN 6885, Sheet 1, Form A

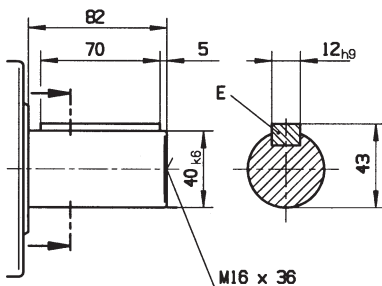

Involute according to DIN 5480 in mm

X = W 40 x 2 x 30 x 18 x 6m, DIN 5480

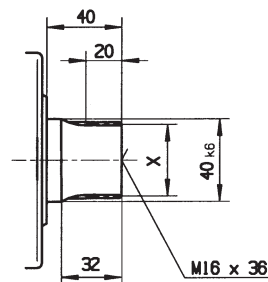

Please contact alpha for optimal sizing at S1 operating conditions (continuous duty).

Conversion table

1 mm	= 0.039 in
1 Nm	= 8.85 in.lb
1 kgcm ²	= 8.85 x 10 ⁻⁴ in.lb.s ²
1 N	= 0.225 lb _f
1 kg	= 2.21 lb _m

2-stage

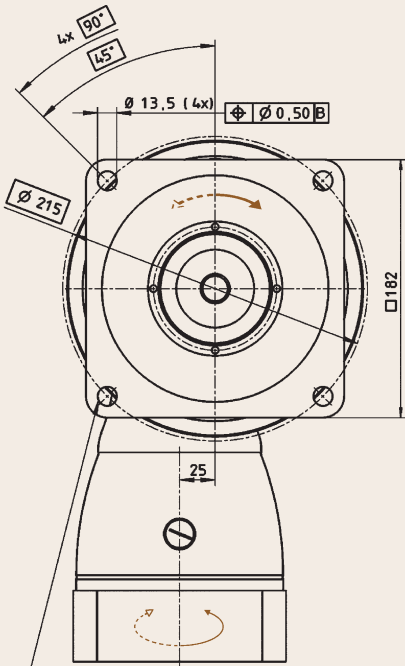

For 4x screw M12 / strength category 12.9

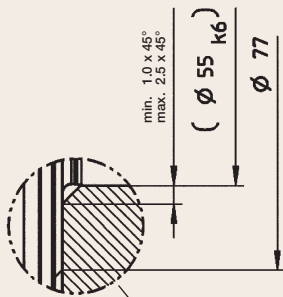
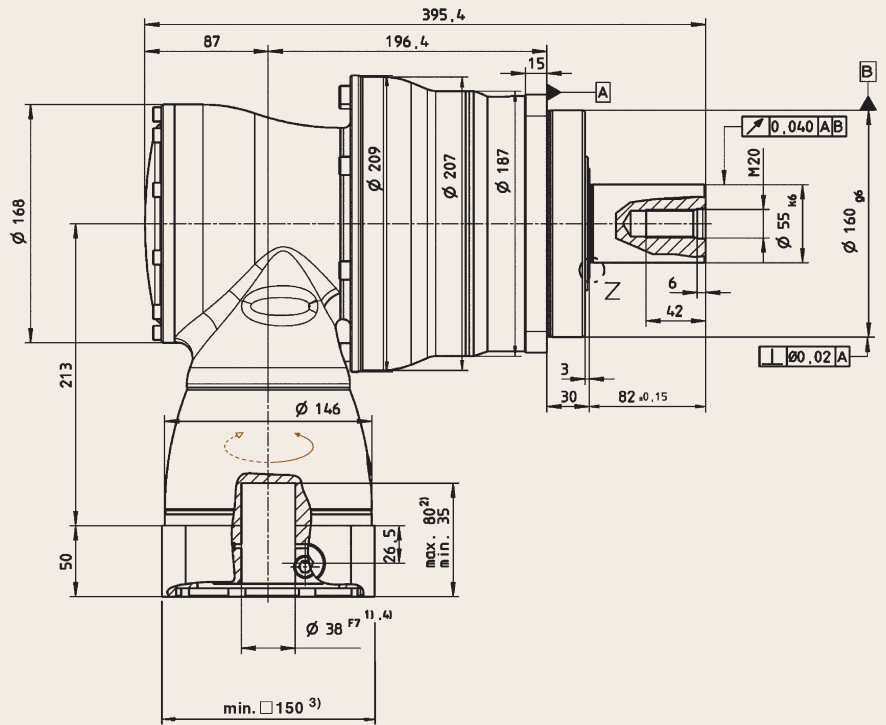

Z: Connecting part

Non-toleranced dimensions ±1 mm

- 1) Check motor shaft fit.
- 2) Min./max. permissible motor shaft length. Longer motor shafts are possible on request: please contact alpha.
- 3) Dimensions depend on motor.
- 4) Smaller motor shaft diameters possible using a bushing with a minimum wall thickness of 1 mm (see page 26).

⚠ Motor mounting in accordance with Operating Manual.

Technical Data SPK+ 180 2-stage

			2-stage									
Ratio *	i		12	16	20	25	28	35	40	50	70	100
Max. acceleration torque (max. 1000 cycles per hour)	T_{2B}	Nm	1100	1100	1100	1100	1100	1100	840	1050	1100	880
Nominal output torque	T_{2N}	Nm	750	750	750	750	750	750	640	750	750	750
Emergency stop torque (Permissible 1000 times during the lifespan of the gearhead)	T_{2Not}	Nm	1600	1600	2000	2000	2750	2000	1600	2000	2750	2200
Nominal input speed at T_{2N} ** (At 20 °C ambient temperature) ***	n_{1N}	min ⁻¹	1600	1900	1900	2100	1900	2100	2100	2100	2100	2100
Max. continuous speed (At 20 °C ambient temperature and 20% T_{2N}) ***	$n_{1N,cym}$	min ⁻¹	2300	2600	2600	2800	2600	3000	3000	3000	3000	3000
No-load running torque ($n_1=3000$ rpm) **** (At 20 °C gearhead temperature)	T_{012}	Nm	9.0	6.5	6.5	5.5	6.0	8.0	6.0	6.0	6.0	6.0
Max. input speed	n_{1Max}	min ⁻¹	4500	4500	4500	4500	4500	4500	4500	4500	4500	4500
Torsional backlash	j_t	arcmin	Standard ≤ 4 / Reduced ≤ 2									
Torsional stiffness	C_{t21}	Nm/arcmin	175									
Max. axial force ****	F_{2AMax}	N	14150									
Max. radial force *****	F_{2RMax}	N	14700									
Max. tilting moment	M_{2KMax}	Nm	1600									
Efficiency at full load	η	%	94									
Service life (see alpha's "Technical Basics" catalogue for calculation)	L_h	h	$\geq 20,000$									
Weight (incl. ADP)	m	kg	45									
Noise level ($n_1=3000$ min ⁻¹) *****	L_{PA}	dB(A)	≤ 70									
Max. permissible housing temperature		°C	+ 90									
Ambient temperature		°C	0 to +40									
Lubrication			Synthetic gear oil									
Paint			Blue RAL 5002									
Direction of rotation			Input and output sides in opposite directions									
Type of protection			IP 65									
Mass moment of inertia (referring to the drive)	J_1	kgcm ²	24.7	19.5	19.0	16.3	18.6	14.0	12.9	12.8	12.7	12.7

- * The binary ratio $i = 32$ is optionally available.
- ** Higher mean speeds are possible at reduced nominal torque.
- *** Please reduce the speed at higher ambient temperatures.
- **** The no-load running torque is reduced in operation.
- ***** In reference to the centre of the output shaft.
- ***** Measured at ratio $i = 40$.

Alternatives: Output shaft version

Keywayed output shaft in mm

E = Key to DIN 6885, Sheet 1, Form A

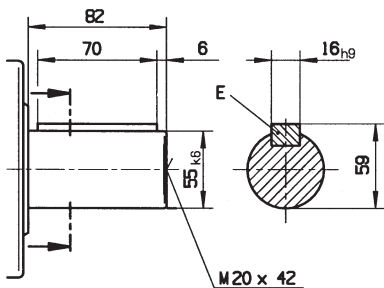

Involute according to DIN 5480 in mm

X = W 55 x 2 x 30 x 26 x 6m, DIN 5480

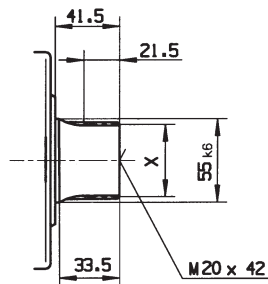

Please contact alpha for optimal sizing at S1 operating conditions (continuous duty).

Conversion table

1 mm	= 0.039 in
1 Nm	= 8.85 in.lb
1 kgcm ²	= 8.85 x 10 ⁻⁴ in.lb.s ²
1 N	= 0.225 lb _f
1 kg	= 2.21 lb _m

SK+/SPK+ innovations:

Extremely easy and reliable motor mounting

The motor shaft is simply clamped with a single bolt

Oil filling independent of the installation position

The revolutionary design principle means the installation position no longer has to be specified in the purchase order.

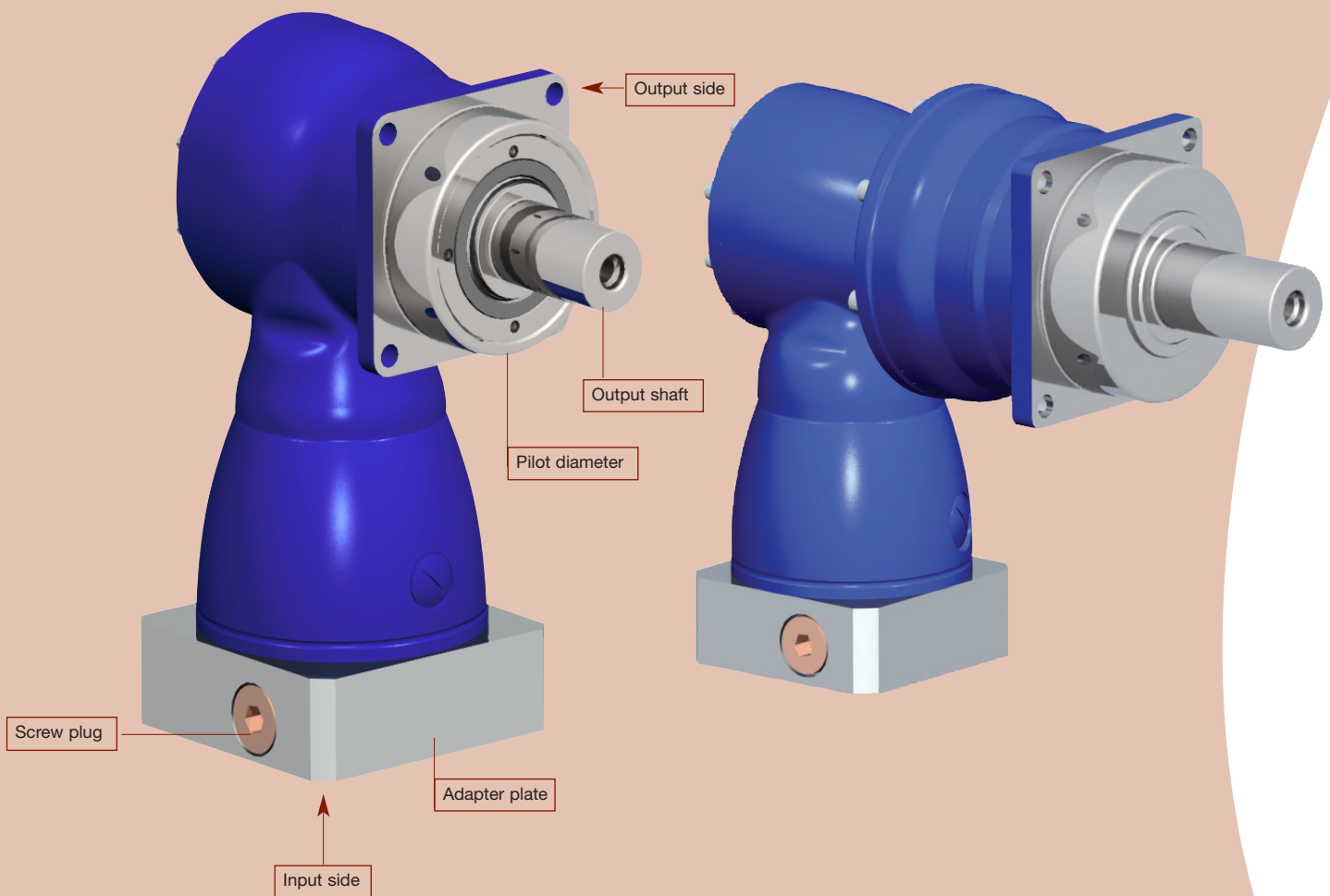

Symbols and Index

Symbol	Unit	Designation
c	Nm/arcmin	rigidity
cym.	rpm	nominal input-speed with 20% T_{2N}
F	N	force
i	-	ratio
j	arcmin	torsionalbacklash
J	kgcm ²	mass moment of inertia
L	h	service life
M	Nm	moment
n	rpm	speed
η	%	efficiency
T	Nm	torque

Index	
1	input
2	output
A/a	axial
B/b	acceleration
h	hours
K/k	tilt
m	mass
Max/max	maximum
Mot	motor
N	nominal
Not/not	emergency stop
0	no-load running
R/r	radial
t	torsional

capital letters
small letters

permissible values
actual values

Quick Gear Selection

For a precise sizing of the gear models we recommend the alpha Technical Basics catalogue (www.alphagear.com). Alternatively, you can use alpha's cymex® 3.0 software for sizing the gear and for calculating your whole drivetrain.

<p>Cyclic operation S5 Number of cycles ≤ 1000/hour</p> <p>Duty cycle $< 60\%$ and < 20 min.*</p>	<ol style="list-style-type: none"> Using servomotor characteristic data, determine the maximum motor acceleration torque: T_{MaxMot} [Nm] Determine maximum acceleration torque at the gearhead output: T_{2b} [Nm] $T_{2b} = T_{MaxMot} \cdot i$ (ratio) Compare the maximum acceleration torque just calculated with the permissible acceleration torque (T_{2B}) for the selected gearhead from Requirement: $T_{2b} \leq T_{2B}$ If not, choose another gearhead. 	<ol style="list-style-type: none"> Verify that the clamping hub diameter (table on page 26) is OK for the selected servomotor. Compare the motor shaft length, L_{Mot} (mm), with the min. and max. clamping hub depth in the dimensional sketches.
<p>Continuous operation S1</p> <p>Duty cycle $\geq 60\%$ or ≥ 20 min.*</p>	<ol style="list-style-type: none"> Calculate after checking for cyclical operation S5. Determine the motor nominal torque: T_{1NMot} [Nm (in.lb)] Determine the rated load torque at the gearhead output: T_{2n} [Nm] $T_{2n} = T_{1NMot} \cdot i$ (ratio) 	<ol style="list-style-type: none"> Compare the calculated rated load torque with the permissible rated torque (T_{2n}) for the selected gearhead. Requirements: $T_{2n} \leq T_{2N}$ If not, choose another gearhead. Determine the nominal input speed n_{1n} in rpm and compare with permissible nominal input speed of the gearhead, n_{1N}. Requirements: $n_{1n} \leq n_{1N}$ Verify proper clamping hub diameter and motor shaft length as in steps 4 & 5 above (S5).

* General guidelines for most applications. Contact alpha if assistance is needed for special cases.

Ordering key

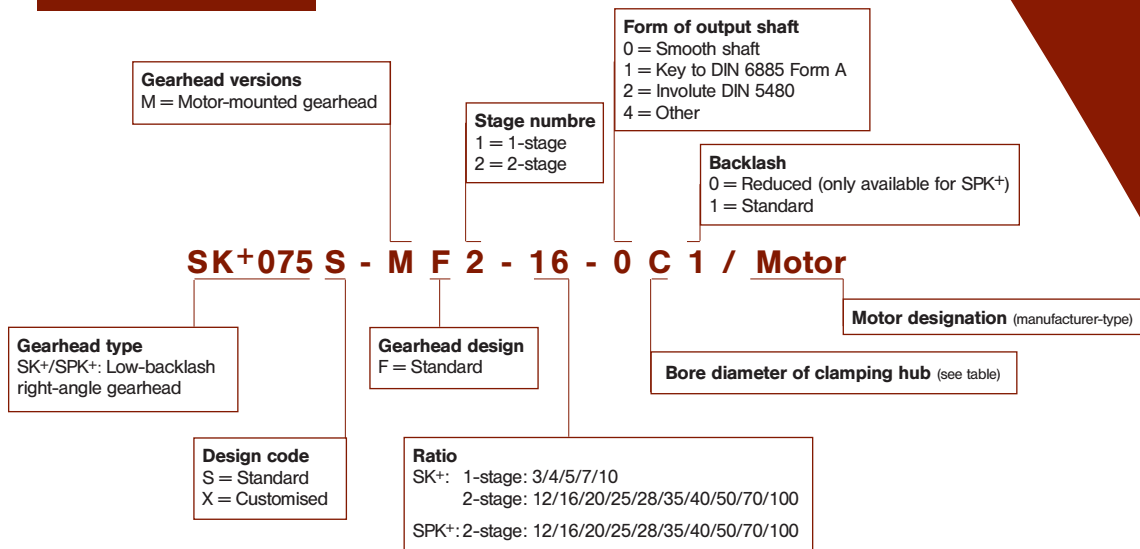

Table of clamping hub diameters

Gearhead stages	SK+					SPK+			
	1 / 2	1 / 2	1 / 2	1 / 2	1 / 2	2	2	2	2
Motor shaft diameter (mm)*	060	075	100	140	180	075	100	140	180
11	- / B	- / -	- / -	- / -	- / -	-	-	-	-
14	C / +	- / C	- / -	- / -	- / -	C	-	-	-
19	E** / +	E / +	- / E	- / -	- / -	E**	E	-	-
24	+ / +	- / +	- / +	- / G	- / -	+	-	-	-
28	+ / +	H** / +	H / +	- / +	- / -	+	H**	H	-
38	+ / +	+ / +	K** / +	K / +	- / K	+	+	K**	K
48	+ / +	+ / +	+ / +	M** / +	M / +	+	+	+	M**

- Select next higher letter
+ Select next larger gearhead

* If your motor shaft diameter is not listed, add 2 mm to diameter and select next higher size.
** Geometry not shown in the drawings; dimensions available upon request.

Bushing

If the diameters of the motor shaft and the clamping hub do not match, a bushing is used.
Minimum wall thickness of the bushing is 1 mm.

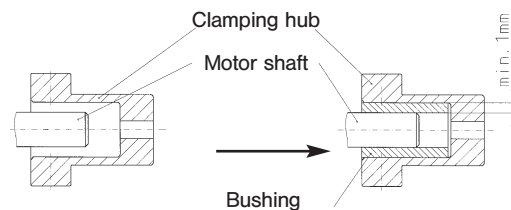

alpha's cymex® calculation software makes it easier than ever to design the most complex drive trains with just a few mouse clicks.

application – gearhead – motor

cymex® simplifies technical documentation, and customised engineering designs are possible at any time thanks to data in DXF format.

Use cymex®.

easy – quick – reliable

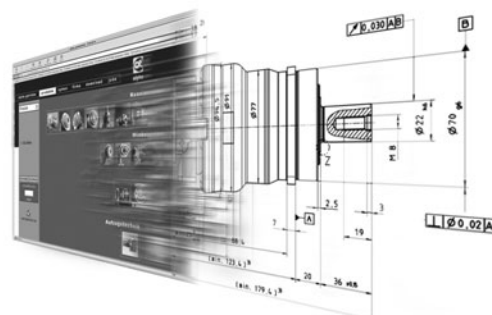

Additional **alpha** products



TP+ & TP+ HIGH TORQUE® – Compact Precision

Low-backlash planetary gear reducers with output flange. Torsional backlash ≤ 1 arcmin. Acceleration torque up to 10,000 Nm. TP+ HIGH TORQUE best qualified for highest positioning accuracy and high-dynamic cycle operation.



SP+® & SP+ HIGH SPEED® – The New Generation

Low-backlash planetary gear reducers with output shaft. Torsional backlash ≤ 1 arcmin. Acceleration torque up to 3400 Nm. SP+ HIGH SPEED best qualified for highest speed in continuous operation.



LP+ & LPB+ – Value Line

Low-backlash gear reducers with output shaft for economical servo applications. Torsional backlash ≤ 10 arcmin. Acceleration torque up to 450 Nm. Optional available as LPB+, with geared pulley mount.

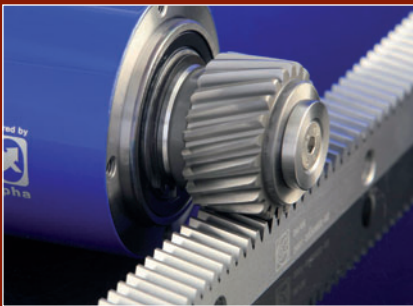

Rack & Pinion System

PREMIUM CLASS
For exacting dynamics and precision requirements in high-end applications
SMART CLASS
For flexible mounting with more degrees of freedom in mid-range applications
VALUE CLASS
For standard linear tasks in economy applications



Hypoid Gearhead

Right-angle gearhead of highest precision and compactness. Torsional backlash ≤ 4 arcmin. Acceleration torque up to 640 Nm. Output shaft variations: SK+: smooth, keywayed, involute toothing to DIN 5480, TK+: flange HG+: hollow shaft



Hypoid Planetary Gearhead

Right-angle planetary gearhead of highest precision and power density. Torsional backlash ≤ 2 arcmin. Acceleration torque up to 1600 Nm. Output shaft variations: SPK+: smooth, keywayed, involute toothing to DIN 5480, TPK+: flange

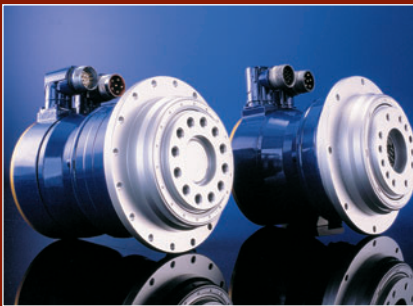

TPM & TPMA - Servoactuators

Ultra-compact and highly precise brushless gear motors featuring high dynamics, high torsional stiffness and a backlash of just 1 to 3 arcmin. Acceleration torque up to 2600 Nm. Up to 60 % shorter overall length and much lower weight than conventional servomotor-gearhead designs.



Coupling – TL / BC / EC

Patented, backlash-free, compact and torsionally stiff metal bellows and safety couplings. Acceleration torque up to 10,000 Nm Disengagement in 1 – 3 ms Belt tension 100 – 12,000 N. Self-adjusting

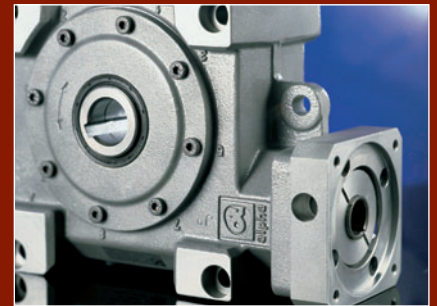

V - Drive®

Right-angle gearhead – short and compact. Torsional backlash ≤ 3 arcmin. Acceleration torque up to 718 Nm. Options output: VDS: smooth, keywayed, involute toothing to DIN 5480, VDT: flange VDH: hollow shaft smooth or keywayed.

For further information, order your personal brochure from:
Phone +49 7931 493-0

or download the digital version:
www.alphagetriebe.com

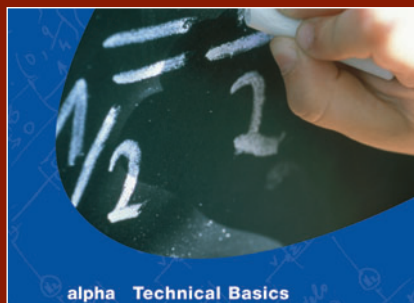

alpha international:



alpha getriebebau GmbH
Walter-Wittenstein-Str. 1
97999 Igersheim · Germany

Phone: +49 7931 493-0
Telefax: +49 7931 493-200
info@alphagetriebe.de
www.alphagetriebe.de



alpha

a **WITTENSTEIN AG** company